

ASSEMBLY INSTRUCTIONS

Hi-Rise

18K 5TH WHEEL CONVERSION HITCH

DEALER/INSTALLER:

(1) Provide this Manual to end user.

END USER:

- (1) Read and follow this Manual every time you use Hitch.
- (2) Save this Manual for future reference.
- (3) Pass on copies of Manual to any other users or owners of the Hitch.

This hitch is designed to work with *Cequent* (94XX) series gooseneck heads utilizing the (44XX) series rails only using the round post assembly. By using the square post assembly this hitch will also work with the B & W gooseneck hitch.

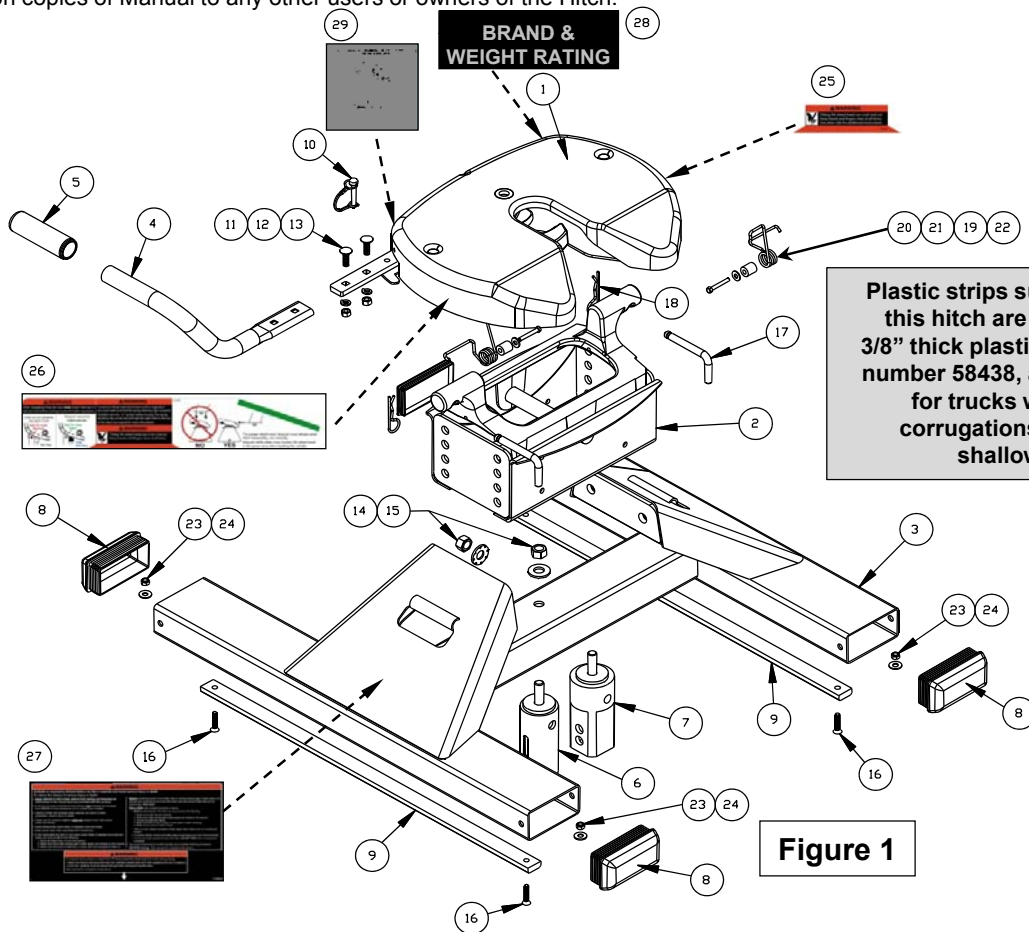

Figure 1

REF #	QTY.	DESCRIPTION
1	1	SKID PLATE ASSEMBLY
2	1	CENTER SECTION
3	1	BASE ASSEMBLY
4	1	HANDLE TUBE
5	1	HANDLE GRIP
6	1	ROUND POST ASSEMBLY
7	1	SQUARE POST ASSEMBLY
8	4	END CAP
9	2	PLASTIC STRIP
10	1	BAIL PIN
11	2	3/8 NUT
12	2	3/8 LOCKWASHER
13	2	3/8 CARRIAGE BOLT
14	2	5/8 CONICAL TOOTHED WASHER
15	2	5/8 NYLON LOCK NUT

REF #	QTY	DESCRIPTION
16	4	5/16 SCREW
17	2	1/2 PULL PIN 90 DEGREE
18	2	RETAINING CLIP
19	2	FLATWASHER
20	2	TORSION SPRING
21	2	TUBE SPACER
22	2	1/4-20 HEX BOLT
23	4	5/16-18 NYLON LOCK NUT
24	4	5/16 FLATWASHER
25	1	LABEL, PINCH POINT
26	1	LABEL, OPERATING WARNING
27	1	LABEL, WARNING
28	1	LABEL, RATING
29	1	HANG TAG
30	1	5/8" KNURL BOLT

⚠ WARNING:

Failure to follow all of these instructions may result in death or serious injury!

INDEX

1. GUIDELINES FOR MATCHING TOW VEHICLE AND TRAILER	P. 2-4
2. PLASTIC BED LINER INSTRUCTIONS	P. 5
3. ASSEMBLY INSTRUCTIONS	P. 6-11
4. CEQUENT PERFORMANCE PRODUCTS TWO YEAR LIMITED WARRANTY	P. 12

Section 1 - GUIDELINES FOR MATCHING HITCH, TRUCK, AND TRAILER

⚠ WARNING:

Failure to check and follow tow ratings could result in tow vehicle damage or truck and trailer separation while towing.

- Trailer and its contents together must not exceed truck, hitch and/or trailer tow ratings.
- Towing vehicle must have a manufacturer's rated towing capacity equal to or greater than the gross trailer weight (dry weight of the trailer plus payload of the trailer). (See Fig. 2)
- Gross weight of trailer must not exceed 18,000 pounds.
- King pin weight must not exceed 4,500 pounds (See Fig. 3). If in doubt have king pin weight measured by qualified facility.

Figure 2



1. Check Tow Ratings:

Vehicle Tow Rating: _____.

Hi-Rise Hitch Rating: 18,000 lbs.

Gross Trailer Weight (figure 2): _____.

***Trailer weight should be the lowest of these recorded ratings for safe towing conditions.**

2. **Cequent Performance Products** hitches are designed for use with recreational fifth wheel trailers only. Hitch applications other than recreational fifth wheel trailers must be approved in writing by **Cequent Performance Products'** Engineering Department.
3. Use only a SAE 2-inch kingpin with your **Hi-Rise Fifth Wheel Conversion Hitch**.
4. Approximately 15%-25% of trailer weight should be on hitch (Pin Weight). See Fig. 3.

Figure 3

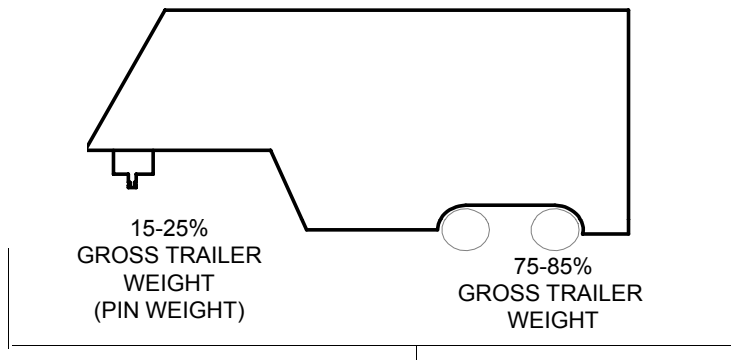

5. Trucks come in many different configurations. **Cequent Performance Products** hitches are designed for use in light trucks such as the Ford F-Series, the Chevy Silverado, Dodge Ram and the Toyota Tundra. **Cequent Performance Products** recommends the use of long bed (8ft) trucks for the best combination in truck - trailer turning clearance.

Rule of thumb: The distance from the back of the truck cab to the center of the rear truck axle ("X" in Fig. 4), should be approximately 4 inches greater than one-half the trailer width ("Y" in Fig.4)

Figure 4

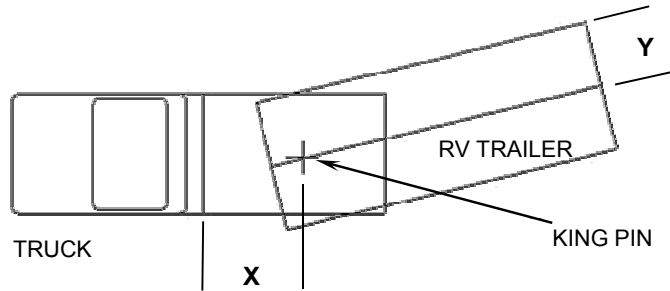

6. If a short bed pickup (less than 8 ft. but longer than 6 ft.) is to be used for towing, **Cequent Performance Products** recommends the trailer be equipped with a minimum 13" extended pin box to help gain additional truck - trailer turning clearance (See trailer manufacturer for options) (See Fig. 5).

Figure 5

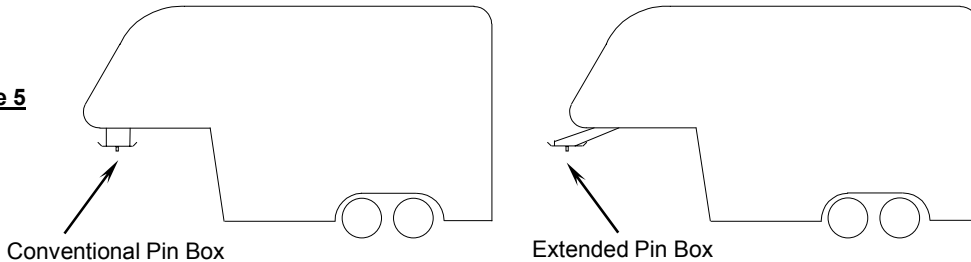

⚠ WARNING:
Do Not install this fifth wheel hitch on or attempt to tow with a short bed pickup truck that has a bed shorter than 6 ft.! Doing so could result in vehicle damage, Serious injury, or Death

7. The height of the hitch and the pin box should be adjusted so the trailer is approximately level as it is towed. Allow approximately 6 inches clearance between the top of the pickup walls and the underside of the front of the trailer for pitch and roll of the trailer. (See Fig. 6). For off road use allow more clearance between pickup walls and trailer.

Figure 6

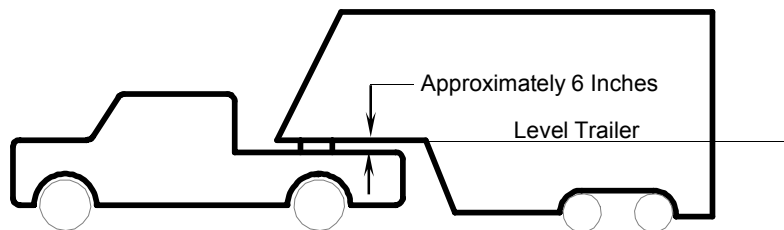

CAUTION:
 The measurements above are guidelines. If your measurements are close to these numbers re-check clearances. If vehicle and/or trailer has any added bed vicinity accessories (i.e. fairings, air dams, ground effects, bed rails, etc.). Additional dimensioning and clearance checks have to be made.

8. Hitch height determination:
With trailer leveled and on level ground measure from the ground to the king pin box, "A" in Figure 7. Secondly measure from the height of the inside of the truck bed, "B" in Figure 7. Dimensions "C" and "D" in Figure 7 can be used to determine the amount of clearance over the side rails, as mentioned in Note 7.

$$\text{Hitch Height} = A - B + 2"$$

The 2" value is an estimate of suspension compression due to king pin weight of the trailer. This compression could range between 1"-5" depending on the truck being used and the trailer being towed.

$$D - C + 2" > 6" \text{ as stated in Note 7.}$$

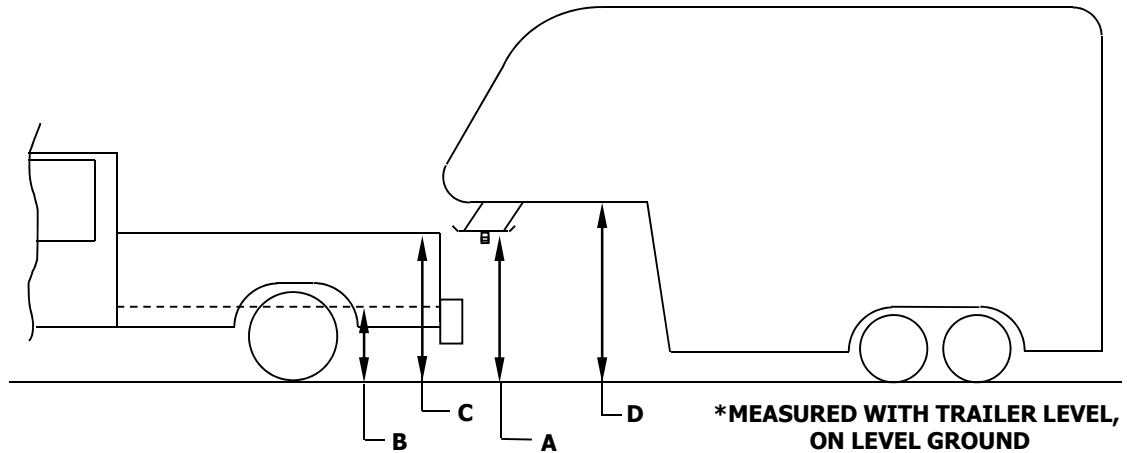

Figure 7

9. If a lube plate is to be used with a Hi-Rise 5th Wheel Conversion Hitch, it must be at least 12" in diameter and not more than 3/16" thick. Cequent Performance Products offers this optional lube plate as part # 83001 / 40001.

⚠ WARNING:

- Connection for trailer wiring must be located at the side of the truck bed between the driver's seat and the rear wheel to prevent operators from working between the truck and trailer.
- Avoid putting any part of your body under the trailer or between the truck and trailer. Unexpected or accidental movement of the truck or the trailer can cause serious injury or death
- If you must place any part of your body under the trailer or between the truck and trailer you **MUST** perform **ALL** of the following steps:
 - Check that the truck transmission is in park
 - Check that the emergency brake is set
 - Block in front of and behind all trailer tires
 - Check that the trailer landing gear are resting on firm ground

Printed In China

If your truck is equipped with a plastic bed liner, then cutting or removal of the plastic bed liner **WILL** be necessary for the proper installation and operation of the **18K Hi-Rise Fifth Wheel Conversion Hitch**. Refer to the "Plastic Bed Liner Instructions" portion below for instructions on one option for cutting your plastic bed liner if required. If your truck is not equipped with a plastic bed liner or if it has a spray in bed liner, then you should use the instructions provided in the mounting kit for your specific truck and skip to page 6 for the rest of the **18K Hi-Rise Fifth Wheel Conversion Hitch** instructions.

Plastic Bed Liner Instructions:

1. **Note!** Before cutting check with vehicle owner to confirm that they want liner to be cut. Liner can be removed totally as an option.
2. Follow the mounting kit instructions for your specific vehicle.
3. Measure and mark the distances provided in **Figure 8** for the areas to be cut out of your plastic bed liner. This is just one option, check with vehicle owner to discuss other ways to cut liner or remove liner and leave out.
4. Remove the plastic bed liner from your truck and cut out the marked areas with a saw or cutting device of your choice.
5. Reinstall the plastic bed liner.
6. Continue the rest of the **18K Hi-Rise Fifth Wheel Conversion Hitch** instructions.

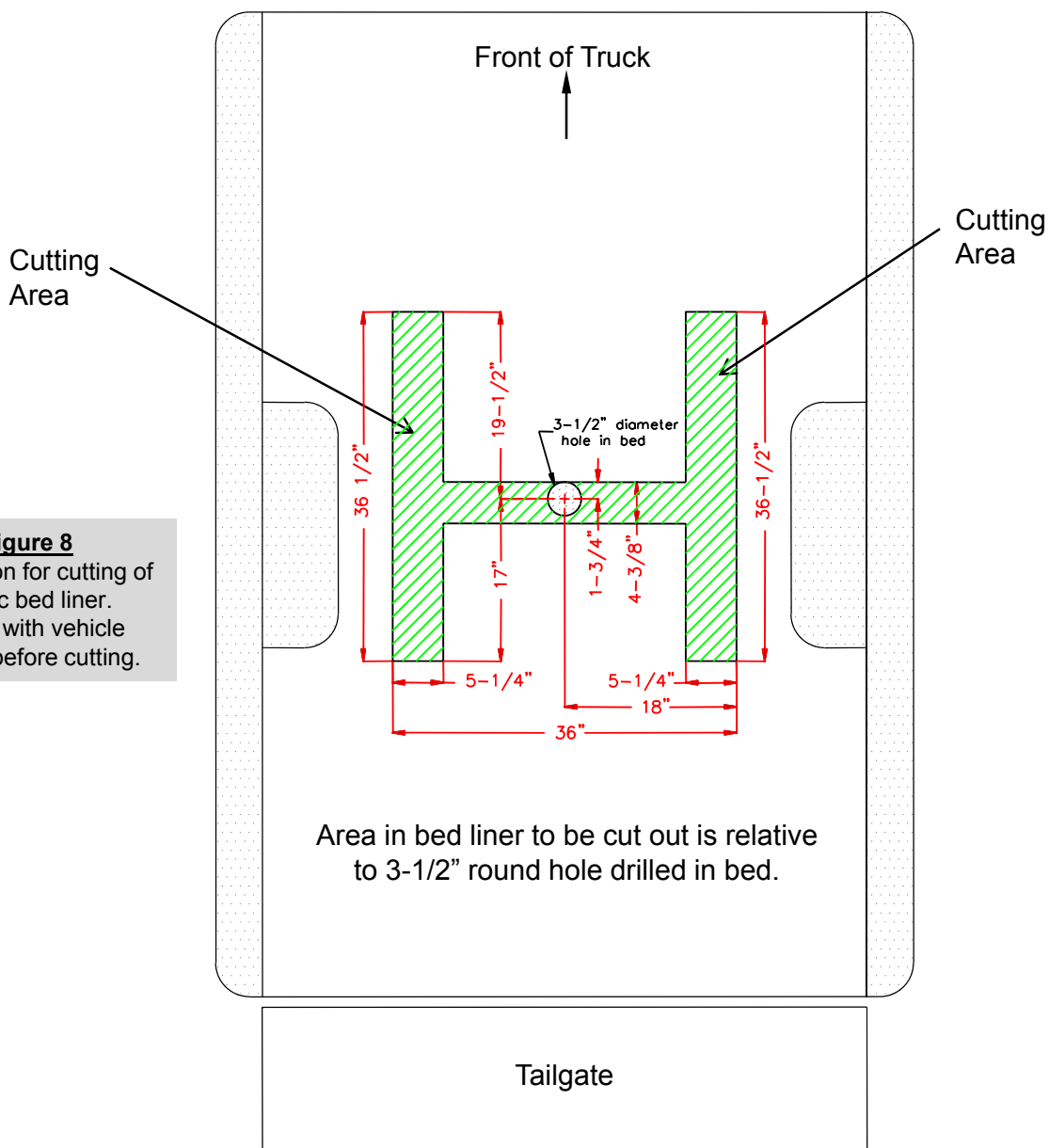

Figure 8
One option for cutting of plastic bed liner. Check with vehicle owner before cutting.

Area in bed liner to be cut out is relative to 3-1/2" round hole drilled in bed.

**ASSEMBLY AND ADJUSTMENT
IS REQUIRED BEFORE INITIAL USE.**

**SOME USERS MAY REQUIRE MORE EXTENSIVE ADJUSTMENTS. THE TOOLS NEEDED FOR THESE
ADJUSTMENTS ARE LISTED BELOW.**

POSSIBLE TOOLS NEEDED IF FURTHER ADJUSTMENT ARE REQUIRED

7/16", 9/16" and 15/16" Socket, Open End Wrenches, Phillips Screw Driver,
200 lb-ft Torque Wrench

1. Check the box for all components listed in **Figure 1** and become familiar with component terminology.
2. Determine from the Guide Lines portion of this instruction sheet (Pages 2 – 4) the height of the hitch that is required and position at the correct setting. See Chart 1 on page 7 as a guide to determine which direction to attach the center section to the base assembly. Attach the center section to the base assembly using the 5/8" Bolts and Lock washers (see Figure 9). Torque the 5/8 fasteners to 170 ft-lb. (230 N*M).

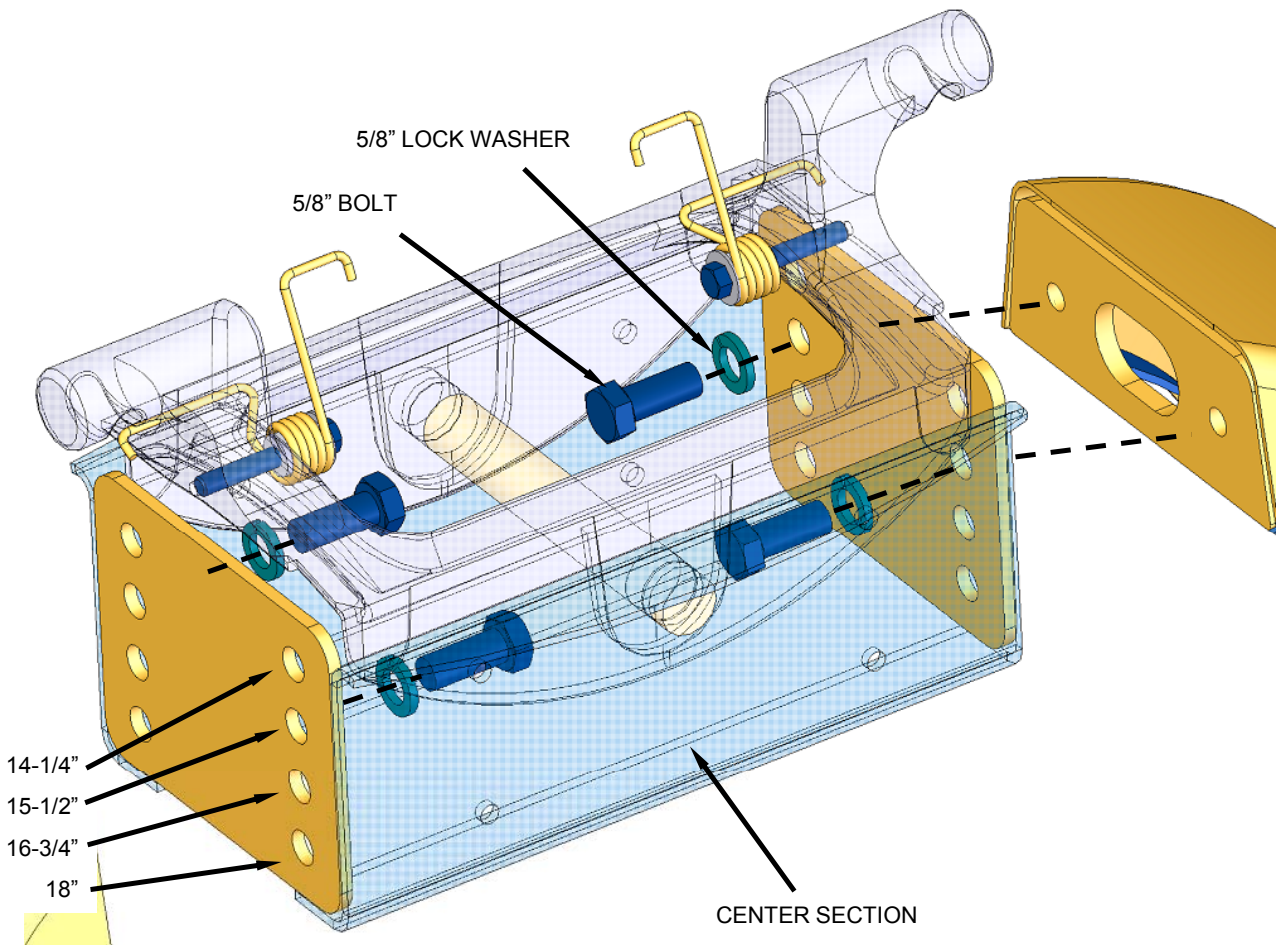

FIGURE 9

Chart 1
See Steps
3A and 3B
below for
spring
adjustment

<u>Year</u>	<u>Vehicle Fit</u>	<u>Center-Section Offset</u>
88- 10	GM 1500/2500/3500 including CKSeries (6' & 8' Beds)	Rearward
04- 10	Ford F-150 6' & 8' Beds	Forward
99- 10	Ford F-250/F-350/F- 450 6' & 8' Beds	Rearward
94- 10	Dodge 1500/2500/3500 6' & 8' Beds	Rearward
07- 10	Toyota Tundra 6' & 8' Beds	Forward

3A. To assemble the spring , use the ¼" bolts, washers, spacers and springs from the fastener kit. **See Figure 10A.**

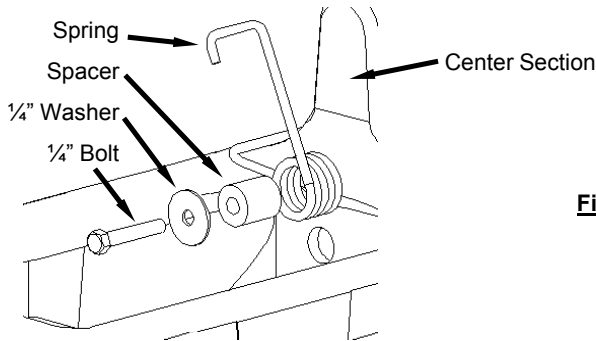

Figure 10A

3B. The coil of the spring (**See Figure 10B**) is facing the rear of the truck and wide hook sits over the center section casting as shown in **Figure 10C**. Assemble and tighten ¼" bolts into the thread holes in the casting.

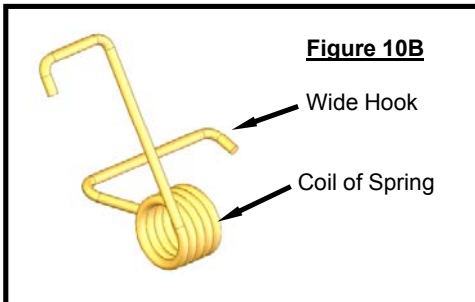

Figure 10B

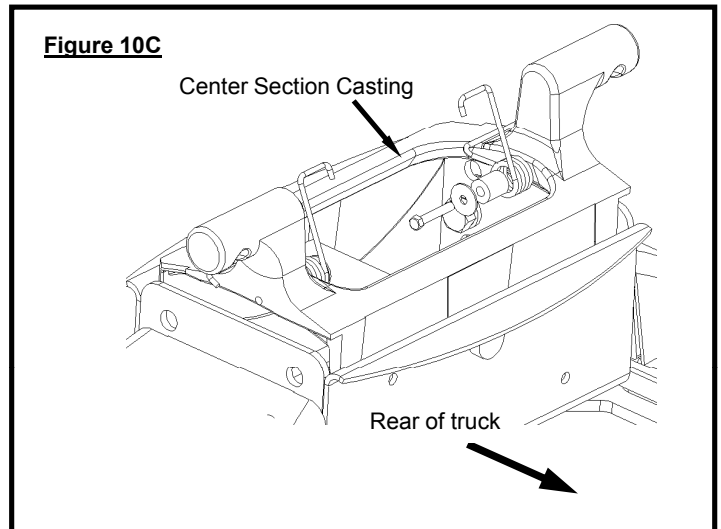
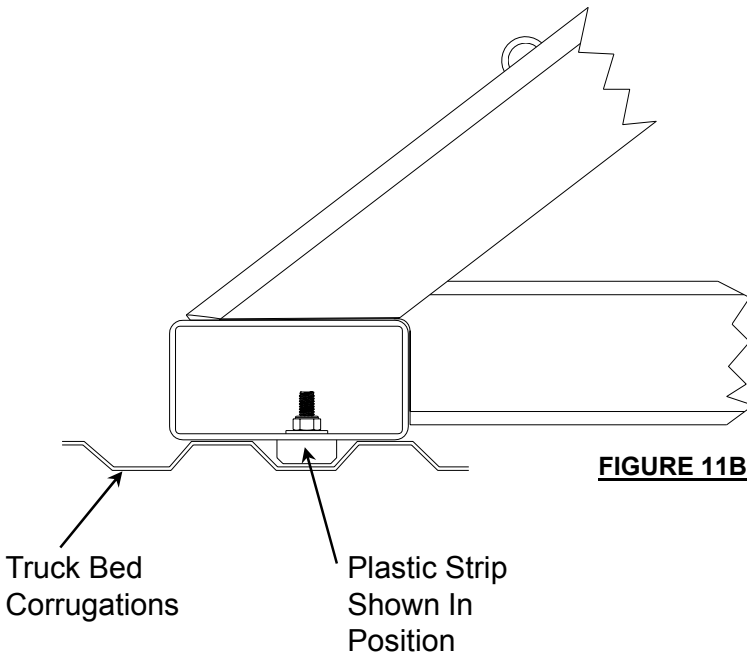
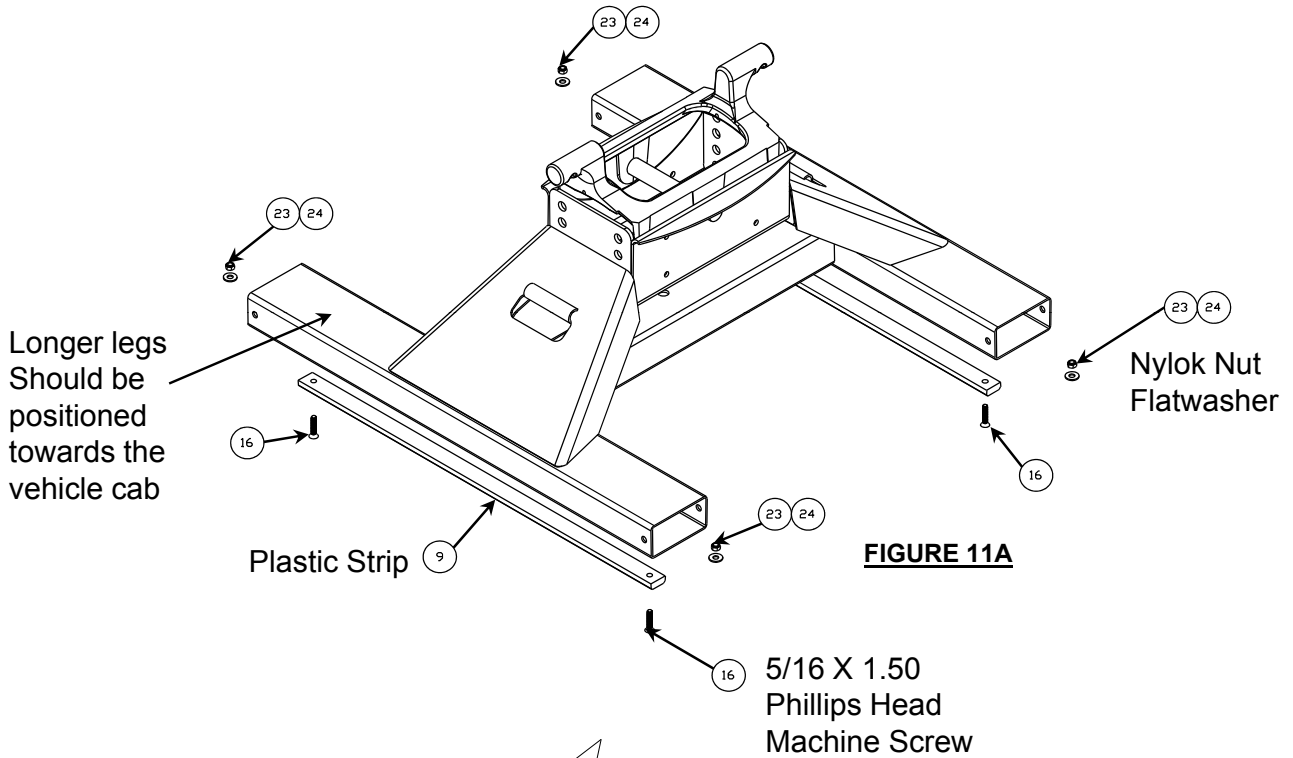

Figure 10C

4. Assemble the plastic strips to the bottom of the legs on the base assembly, using the 5/16 X 1.50 screws, flat washers, and nylon lock nuts. The plastic strips are used to prevent rotation of the hitch and should be aligned so that they sit between the corrugations of the bed as shown in Figure 11B.

NOTE: For the Toyota Tundra the plastic strips should be aligned so that the outer edge of the plastic strip is aligned with the outer corrugation (see figure 11C).



Plastic strips supplied with this hitch are 1/2" thick. 3/8" thick plastic strips, part number 58438, are available for trucks with bed corrugations that are shallower.

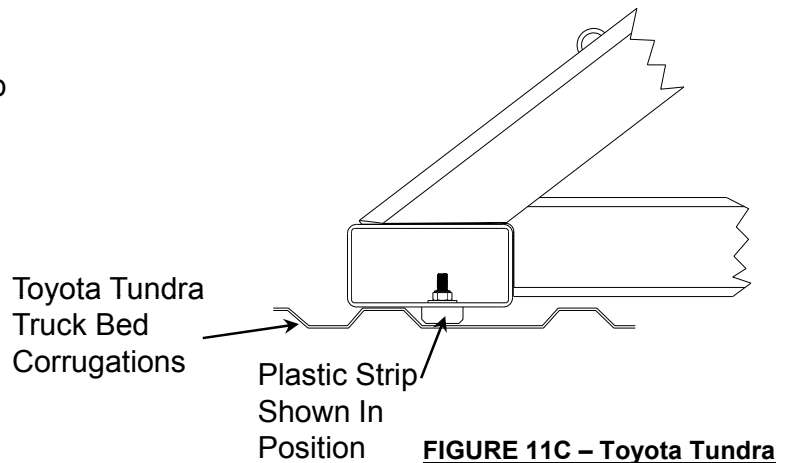

5. Insert the post assembly into the gooseneck hitch as shown in Figure 12. Fishwire the 5/8 knurl bolt through the inside of the post assembly and through the horizontal hole in the post and the slot in the base assembly. Loosely tighten the 5/8" conical toothed washers and nylon lock nuts.
6. Insert plastic end caps into the legs of the Base Assembly.

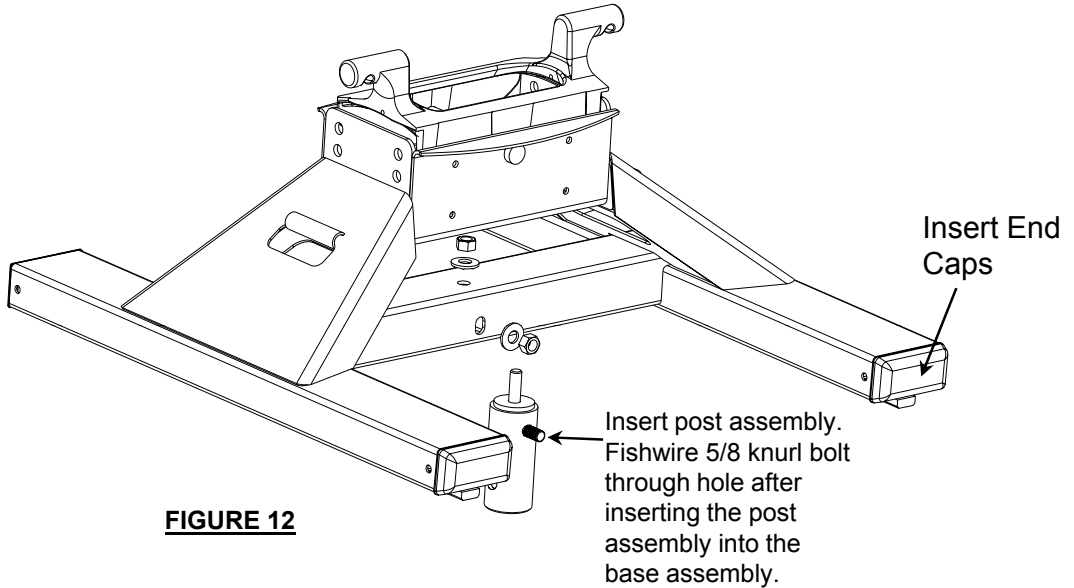

7. Slide the Post Assembly into the gooseneck hitch as shown below in figure 13. The plastic strips should fall into the corrugations on the truck bed if adjusted correctly.

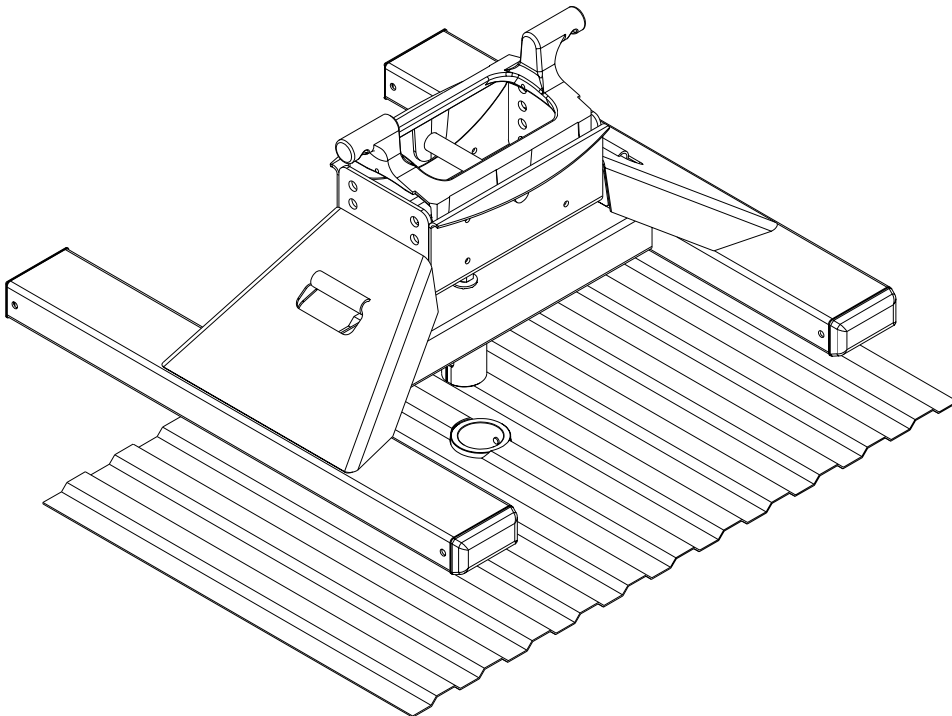

FIGURE 13

8. Align the post assembly into position and close the Handle/Locking Pin mechanism on the gooseneck hitch.

Note: Before towing the 5/8 hex nuts connecting the Post Assembly to the Base Assembly should be torqued to a minimum of 120 ft-lbs. The handle/locking Pin of the gooseneck hitch should not be able to be released when tightened.

9. Lube center section as shown in **Figure 14** with lithium grease.

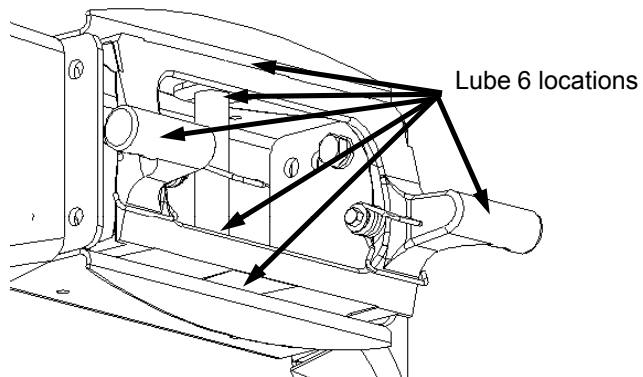

Figure 14

11. Lube pins (2) shown in **Figure 15** with lithium grease prior to installation/operation.

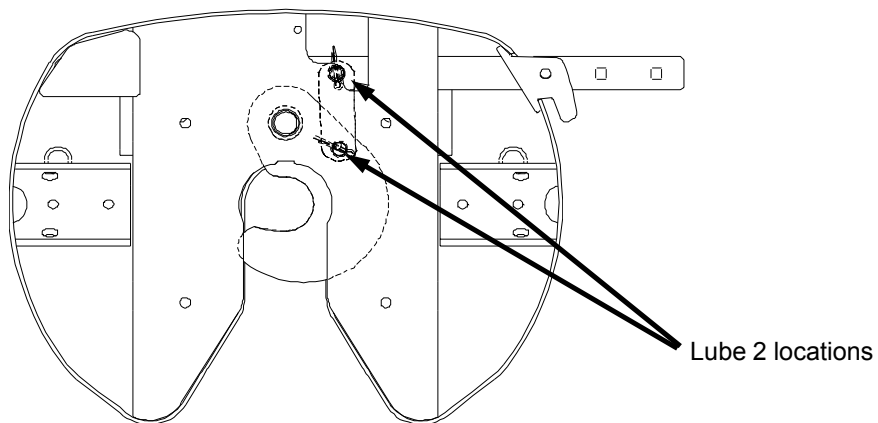

Figure 15

11. Place the skid plate assembly onto the center section assembly. Keep hands clear of pinch points while placing/removing head onto/off hitch base as noted on head labels. Head will tilt rearward.
12. Insert the pull pins and retaining clips shown below. Note that the pull pins used with the Hi-Rise hitch are 90 degree bent pins and if replacements are needed, please contact the factory.
13. Lube jaw and skid plate (If no lube plate is being used) with automotive type chassis grease. The jaw pin comes greased from the factory. To insure smooth jaw operation, grease should be added every 6 months to grease fitting on top of head.

⚠ WARNING:
Tilting 5th Wheel head can crush and cut. Keep hands and fingers clear from this area at all times (including placement/removal of head).

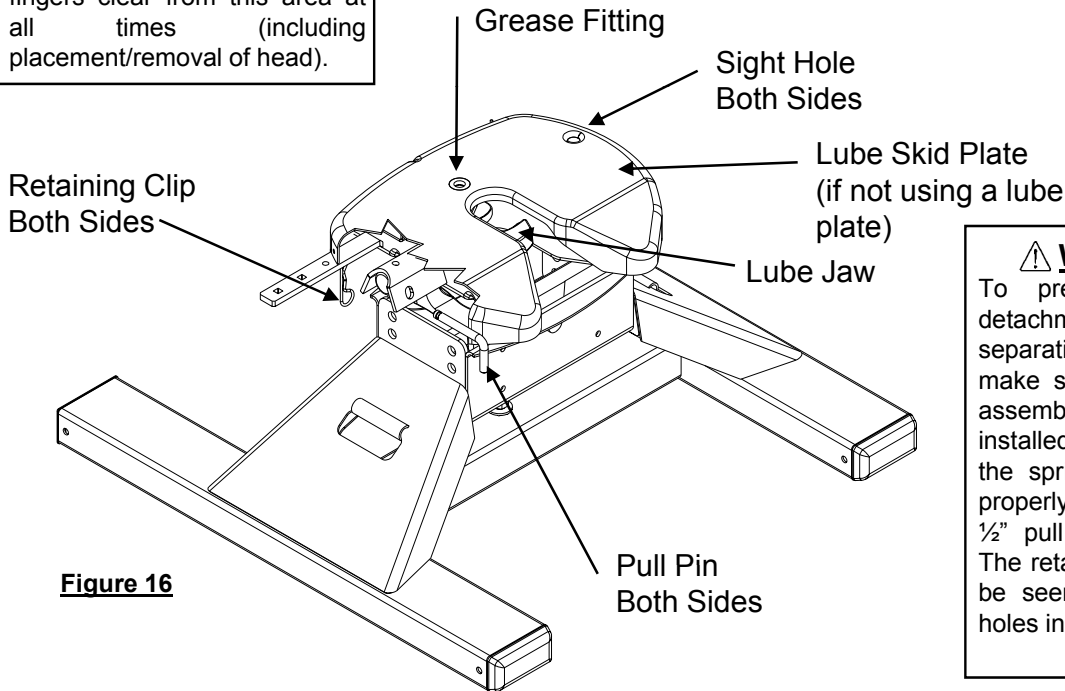

Figure 16

⚠ WARNING:
To prevent tilting head detachment and or separation of hitch you must make sure that the anchor assemblies are properly installed and pinned, and the spring retaining clip is properly installed onto the 1/2" pull pin before towing. The retaining clip can easily be seen through the sight holes in the top of the head.

14. Attach the handle assembly to the skid plate assembly using the 3/8 carriage bolts, lock washer and hex nuts.
15. Slide the handle grip over the handle tube.

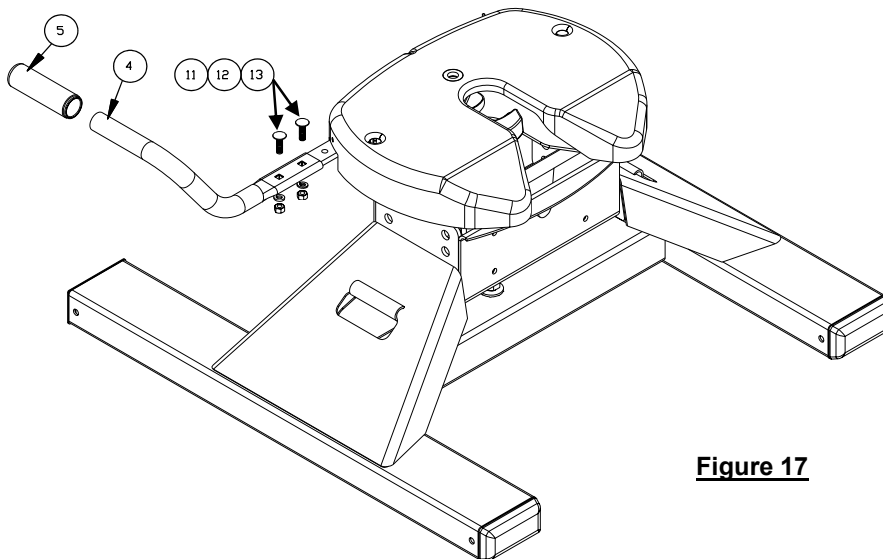

Figure 17

TWO YEAR LIMITED WARRANTY

Cequent Performance Products warrants the **Hi-Rise 5th Wheel Conversion Hitch** from date of purchase against defects in material and workmanship under normal use and service, ordinary wear and tear accepted, for 2 years of ownership to the original consumer purchaser when a **Cequent Performance Products** mounting kit is used.

Cequent Performance Products will replace FREE OF CHARGE any part which proves defective in material or workmanship when presented to any **Cequent Performance Products** dealer, **Cequent Performance Products** warehouse or returned to factory. TRANSPORTATION CHARGES PREPAID, at the address below. THIS WARRANTY IS LIMITED TO DEFECTIVE PARTS REPLACEMENT ONLY. LABOR CHARGES AND/OR DAMAGE INCURRED IN INSTALLATION OR REPLACEMENT AS WELL AS INCIDENTAL AND CONSEQUENTIAL DAMAGES CONNECTED THEREWITH ARE EXCLUDED.

Some states do not allow the exclusion or limitation of incidental or consequential damages, so the above limitation or exclusion may not apply to you.

Any damage to the **5th Wheel Conversion Hitch** as a result of misuse, abuse, neglect, accident, improper installation, or any use violative of instructions furnished by us, WILL VOID THE WARRANTY.

This warranty gives you specific legal rights, and you may also have other rights which vary from state to state. In the event of a problem with warranty service or performance, you may be able to go to a small claims court, or a federal district court.

Cequent Performance Products
47912 Halyard
Plymouth, MI 48170