

Installation Instructions

GOOSENECK MOUNTING KIT Chevrolet/GMC 2500/3500 Heavy Duty Short & Long Bed

Part Numbers:

4456

Equipment Required:

- Fastener Kit:** 4456F
- Wrenches:** 15/16", 15/16" Crowfoot Adaptor
- Drill Bits:** 1/4"
- Other Tools:** Drill, Reciprocating saw
- Optional, Raise Bed:** 18mm socket, 15" extension

WARNING: Under no circumstances do we recommend exceeding the towing vehicle manufacturers recommended vehicle towing capacity.

As an option you can loosen or remove truck bed bolts to raise bed above top of truck frame. This will allow more room to slide rail kits in place. See following pages for detail.

9465/9475 HIDE-A-GOOSE HITCH INSTALLATION

All Fasteners Typical, Both Sides

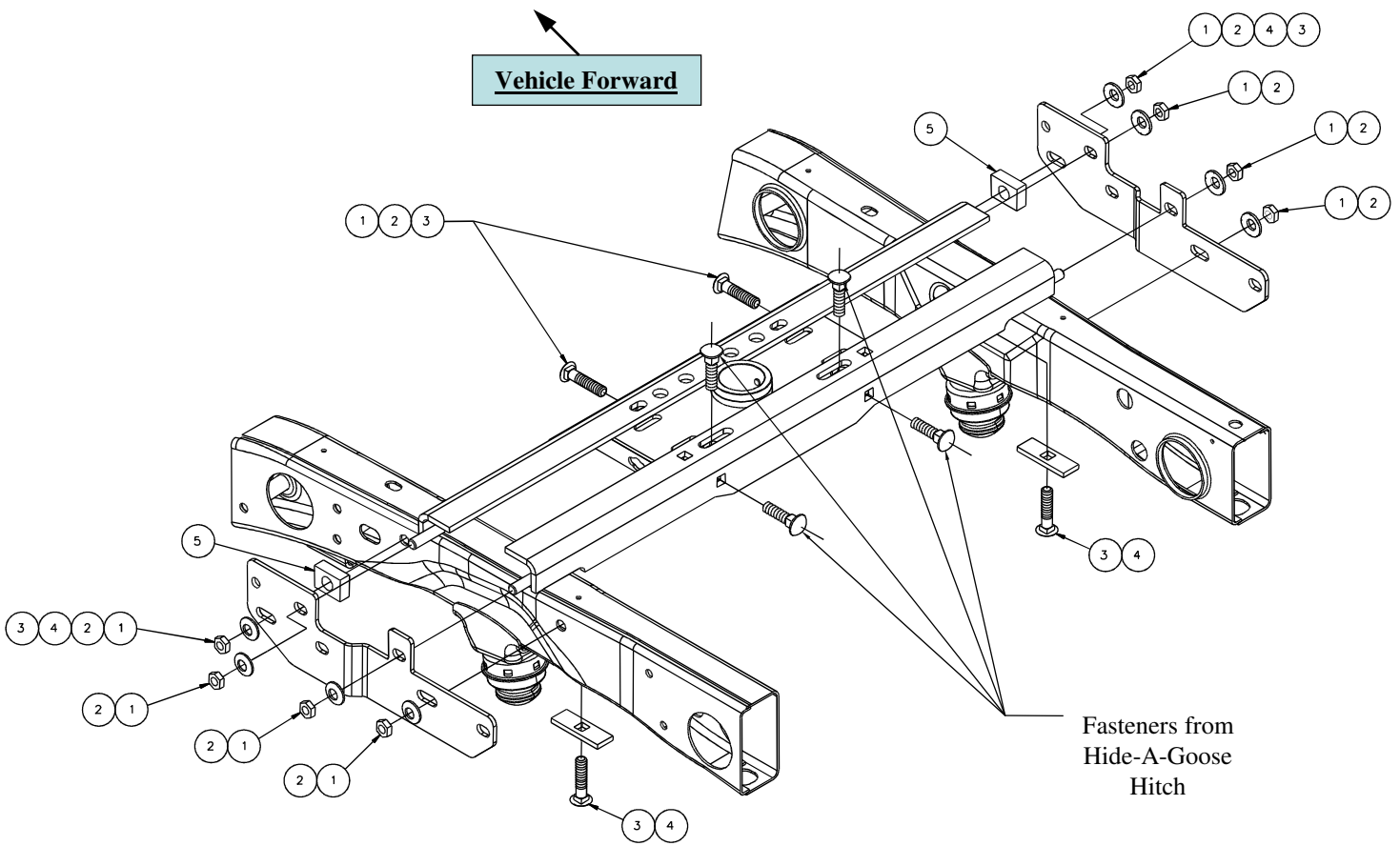

Figure 1

8' Bed Installation Shown

See Figure 6 for 6'-6" bed installation

1	Qty. (10)	5/8-11, Hex Nut	4	Qty. (4)	Block 1/4 X 1.13 x 3.00
2	Qty. (10)	5/8" Conical Toothed Washer	5	Qty. (2)	Block 5/8 X 1.50 X 2.13
3	Qty. (6)	5/8 X 2.50 Carriage Bolt – GR5	6	Qty. (4)	Shims, 5/16 X 2.00 X 1.00 (Not Shown)
z 2011 Cequent Performance Products		Sheet 1 of 8	4456N	8-17-11	Rev. B

Installation Instructions

GOOSENECK MOUNTING KIT

Chevrolet/GMC 2500/3500 Heavy Duty
Short & Long Bed

9465/9475 HIDE-A-GOOSE HITCH INSTALLATION

Part Numbers:

4456

NOTES:

- This section of the instruction refers to installing the 9465 or 9475 head only.
- Always make sure the ball is fully locked before towing.
- Keep the ball and ball sleeve well lubricated.
- Periodically re-torque all the hitch fasteners.
- Check ball, hitch coupler, safety chains and other connections for proper operation every time you tow.

Warning:

- ❖ The tow vehicle manufacturers recommended towing capacities should **UNDER NO CIRCUMSTANCES** be exceeded.
- ❖ Check for adequate clearance between the gooseneck trailer and the rear of the cab and the rear of the truck box before installing hitch.
- ❖ All trucks have fuel lines, brake lines and electrical wiring located along the vehicle frame where the rail kit installs. Carefully examine the location of fuel lines, brake lines and electrical wires before installation and be certain not to damage these when positioning the hitch components. Be careful when drilling holes, cutting sheet metal and tightening fasteners as to not limit the integrity of these systems.

Hide-A-Goose Only – Drilled hole in bed location (see step 3).

Short Box – 44-7/8 inches

Long Box – 45-3/8 inches

Installation Instructions

1. From underneath the passenger's side of the vehicle, remove or cut out the section of the heat shield that is located under the bed, above the exhaust, and between the two bed supports.
2. On short bed models, cut the heat shield on the gas tank or bend the top edge about 1" down to make room for the hitch. See Figure 2. On models with gasoline engines, temporarily detach the fuel vapor pump from the back of the gas tank.
3. When installing the 9465/9475 Hide-A-Goose hitch, a hole must be drilled in the bed of the truck. Mark and drill a 1/4" hole **44-7/8 inches (6'-6" bed) / 45-3/8 inches (8' bed)** from the rear of the bed and centered between the wheel wells. Using a hole saw, enlarge the pilot hole to the final diameter hole size. Refer to the 9465/9475 Hide-A-Goose hitch instruction sheet for hole size.

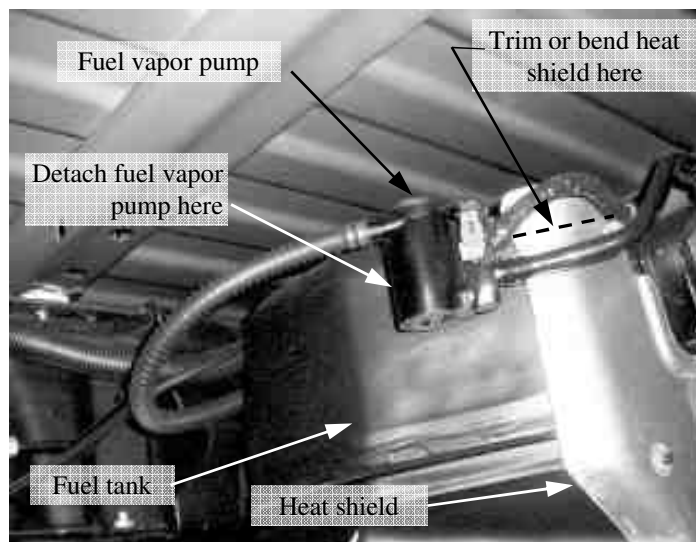

Figure 2
Rear of Gas Tank

Installation Instructions

GOOSENECK MOUNTING KIT

Chevrolet/GMC 2500/3500 Heavy Duty

Short & Long Bed

9465/9475 HIDE-A-GOOSE HITCH INSTALLATION

Part Numbers:

4456

- 4a. **Placing Cross Members Between Bed And Frame: Notching the Side Flange.** From the passenger's side wheel well, notch the sheet metal flange as shown in Figure 3. After notching, the cut steel surfaces should be touched up with paint to prevent rusting.

As an option you can loosen or remove (8) truck bed bolts to raise bed above top of truck frame. This allows room to slide rails in place without notching. Use 15" extension and 18mm socket to loosen/remove bolts from below bed. Keep bed in raised position with wood blocks.

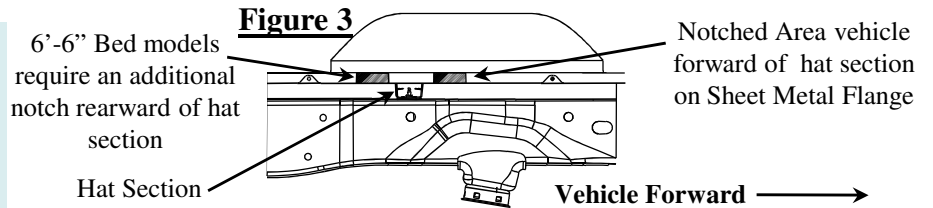

- 4b. **Placing Crossmember Between Bed And Frame: Optional.** On 8' bed models the rails can be installed from underneath the vehicle by placing one end of the rearward crossmember above the vehicle frame and maneuvering the opposite end above the vehicle frame. The forward crossmember can then be installed using the same procedure. See figure 4 for rail installation.

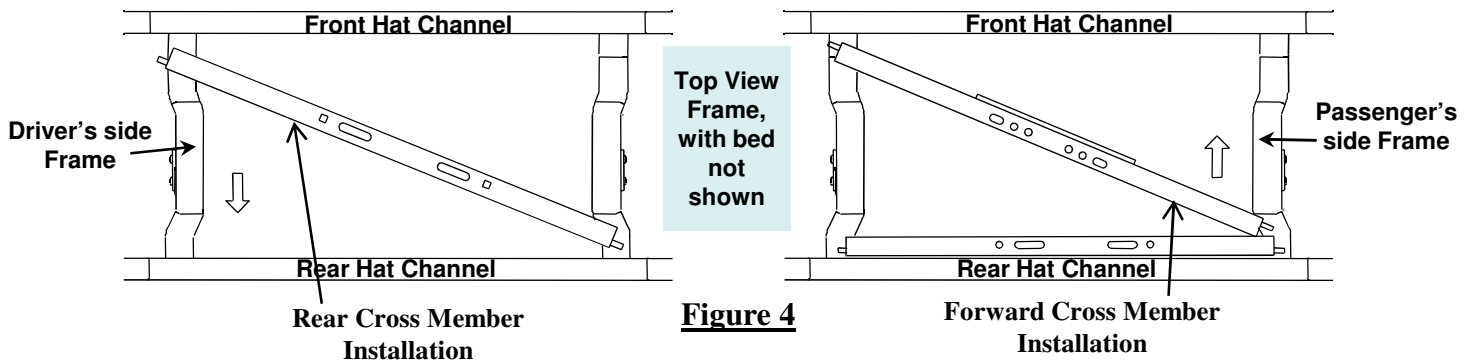

5. Place the 5/8 X 2.00 GR8 carriage bolts from the Hide-A-Goose hitch fastener kit into the long slots on the rearward cross member from underneath the vehicle. Insert the 5/8 X 2.50 GR5 carriage bolts through the square hole on the vertical leg on the forward crossmember.
6. Lift Hide-A-Goose hitch into position and loosely secure the hitch using the 5/8" conical toothed washers and 5/8 hex nuts.
7. Insert the 5/8 X 2.00 GR8 carriage bolts through the square holes in the vertical leg of the rearward crossmember and loosely install the 5/8 conical toothed washers and 5/8 hex nuts (see figure 5 below).

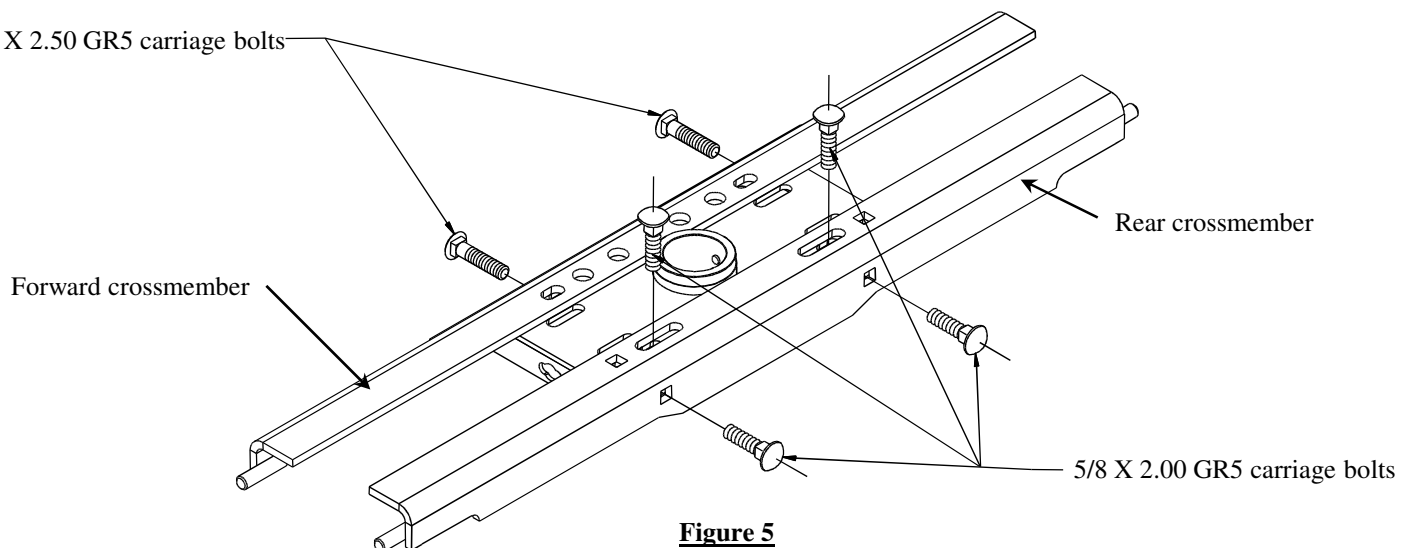

Installation Instructions

GOOSENECK MOUNTING KIT

Chevrolet/GMC 2500/3500 Heavy Duty

Short & Long Bed

9465/9475 HIDE-A-GOOSE HITCH INSTALLATION

Part Numbers:

4456

8. **If truck bed was raised to install rails:** Torque the hitch bolts to the rails now and then remove wood blocks and drop bed down to truck frame aligning head with 3-1/2" diameter hole cut in bed. Reinstall and torque bed bolts.
9. Fishwire 5/8 carriage bolts and 1/4 X 1.13 x 3.00 blocks through the large holes in the vehicle frame rails and through the smaller mounting holes in the frame rails.
10. Position the hitch frame brackets using the hole patterns shown in figure 6 and loosely install the 5/8 conical toothed washers and 5/8 hex nuts.

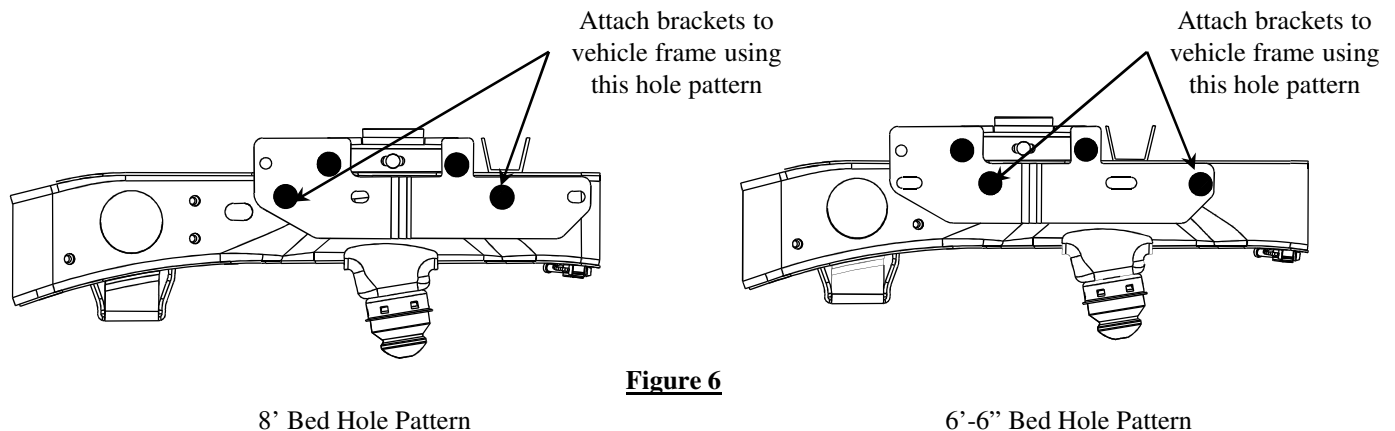

Figure 6

11. Align the studs on the crossmembers with the slots in the frame brackets and loosely install the 5/8 conical toothed washers and 5/8 hex nuts on the studs.
12. Position the Hide-A-Goose hitch with the hole drilled in the bed of the vehicle. Torque the GR8 fasteners on the horizontal leg of the rearward rail to 210 ft.-lb (285 N*m). Using a crows foot adapter torque the GR8 fasteners on the vertical leg of the rearward rail to 150 ft.-lb. (203 N*m). Torque the GR5 fasteners for the forward rail vertical leg attachment to 150 ft.-lb. (203 N*m).
13. Torque the GR5 fasteners attaching the crossmembers to the frame brackets to 150 ft.-lb. (203 N*m). Torque the GR5 fasteners attaching the frame brackets to the vehicle frame rails to 150 ft.-lb. (203 N*m)
14. Reinstall the fuel vapor pump if removed in installation step 2.

Installation Instructions

GOOSENECK MOUNTING KIT Chevrolet/GMC 2500/3500 Heavy Duty Short & Long Bed

Part Numbers:
4456

Equipment Required:

Fastener Kit: 4456F

Wrenches: 15/16"

Drill Bits: 1/4"

Other Tools: Drill, Reciprocating saw

Optional, Raise Bed: 18mm socket, 15" extension

As an option you can loosen or remove truck bed bolts to raise bed above top of truck frame. This will allow more room to slide rail kits in place. See following pages for detail.

WARNING: Under no circumstances do we recommend exceeding the towing vehicle manufacturers recommended vehicle towing capacity.

6300 / 630044 / 8339 GOOSENECK HITCH INSTALLATION

All Fasteners Typical, Both Sides

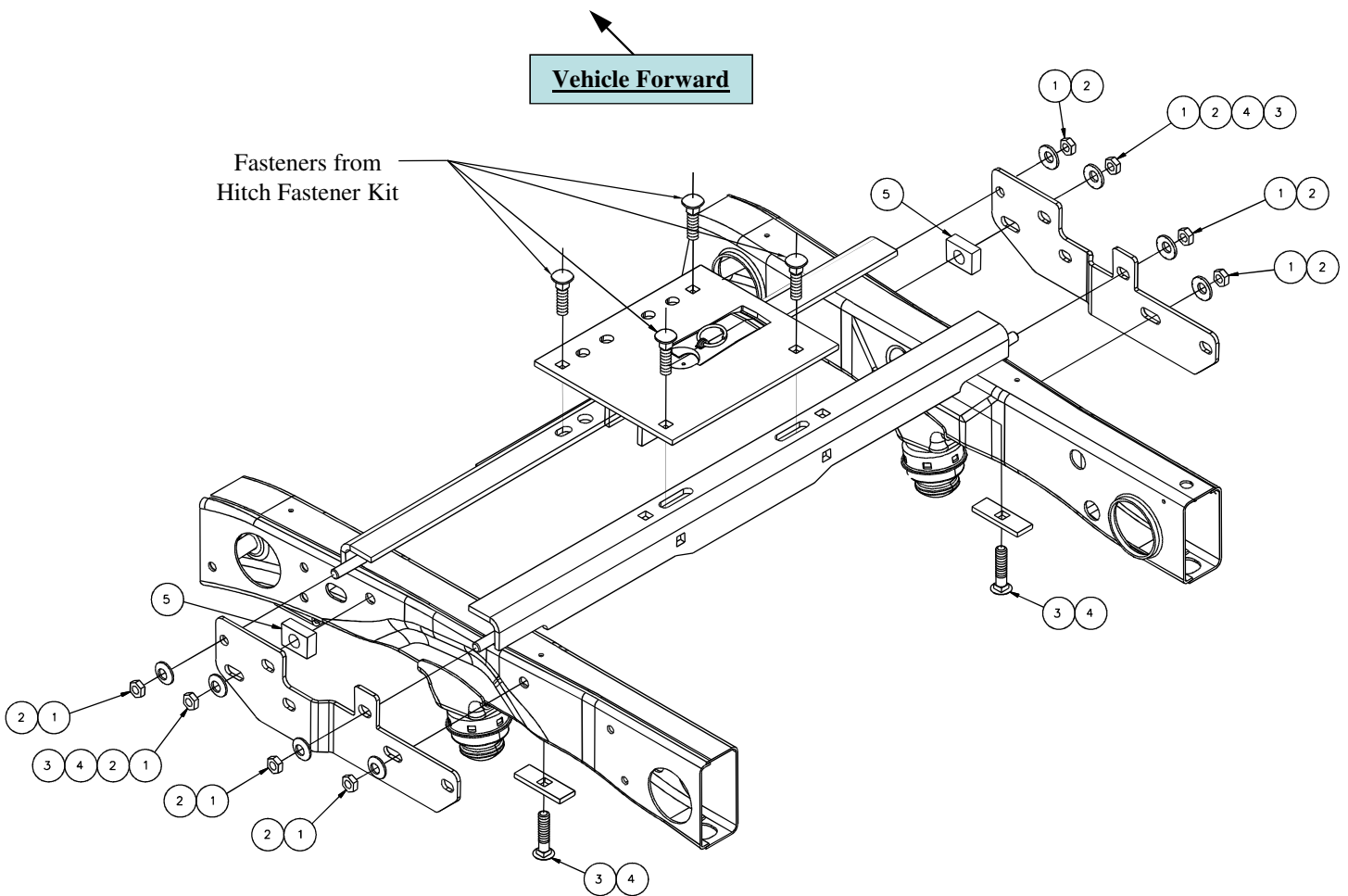

Figure 7

1	Qty. (10)	5/8-11, Hex Nut	4	Qty. (4)	Block 1/4 X 1.13 x 3.00
2	Qty. (10)	5/8" Conical Toothed Washer	5	Qty. (2)	Block 5/8 X 1.50 X 2.13
3	Qty. (6)	5/8 X 2.50 Carriage Bolt – GR5	6	Qty. (4)	Shims, 5/16 X 2.00 X 1.00 (Not Shown)

Installation Instructions

GOOSENECK MOUNTING KIT

Part Numbers:

4456

Chevrolet/GMC 2500/3500 Heavy Duty
Short & Long Bed

6300 / 630044 / 8339 GOOSENECK HITCH INSTALLATION

NOTES:

- This section of instructions refers to installing the 6300, 630044 or 8339 head only.
- Always make sure the ball is fully locked before towing.
- Keep the ball and ball pocket well lubricated.
- Periodically re-torque all the hitch fasteners.
- Check ball, hitch coupler, safety chains and other connections for proper operation every time you tow.

Warning:

- ❖ The tow vehicle manufacturers recommended towing capacities should **UNDER NO CIRCUMSTANCES** be exceeded.
- ❖ Check for adequate clearance between the gooseneck trailer and the rear of the cab and the rear of the truck box before installing hitch.
- ❖ All trucks have fuel lines, brake lines and electrical wiring located along the vehicle frame where the rail kit installs. Carefully examine the location of fuel lines, brake lines and electrical wires before installation and be certain not to damage these when positioning the hitch components. Be careful when drilling holes, cutting sheet metal and tightening fasteners as to not limit the integrity of these systems.

Installation Instructions

1. From underneath the passenger's side of the vehicle, remove or cut out the section of the heat shield that is located under the bed, above the exhaust, and between the two bed supports. On 6'-6" bed models the section of the heat shield located between the rear bed support and the spare tire will also need to be removed.
2. On short bed models, cut the heat shield on the gas tank or bend the top edge about 1" down to make room for the hitch (see Figure 8). On models with gasoline engines, temporarily detach the fuel vapor pump from the back of the gas tank.

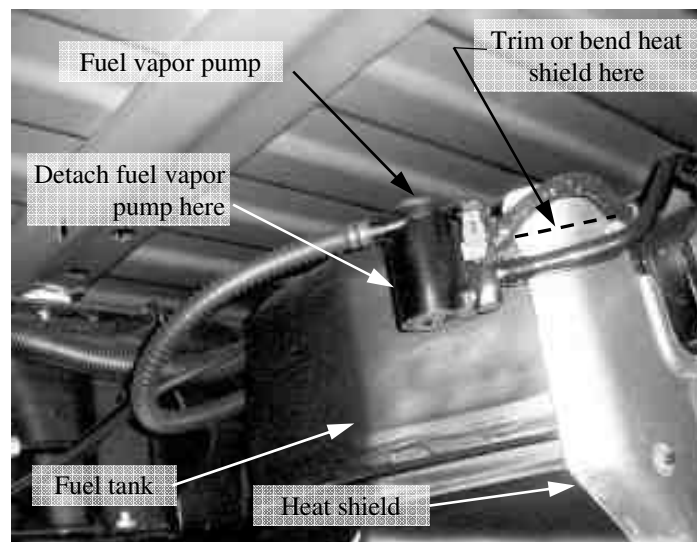

Figure 8
Rear of Gas Tank

Installation Instructions

GOOSENECK MOUNTING KIT

Part Numbers:
4456

Chevrolet/GMC 2500/3500 Heavy Duty
Short & Long Bed

6300/630044/8339 GOOSENECK HITCH INSTALLATION

3a. Placing Cross Members Between Bed And Frame: Notching the Side Flange. From the passenger's side wheel well, notch the sheet metal flange as shown in figure 9. After notching, the cut steel surfaces should be touched up with paint to prevent rusting.

As an option you can loosen or remove (8) truck bed bolts to raise bed above top of truck frame. This allows room to slide rails in place without notching. Use 15" extension and 18mm socket to loosen/remove bolts from below bed. Keep bed in raised position with wood blocks.

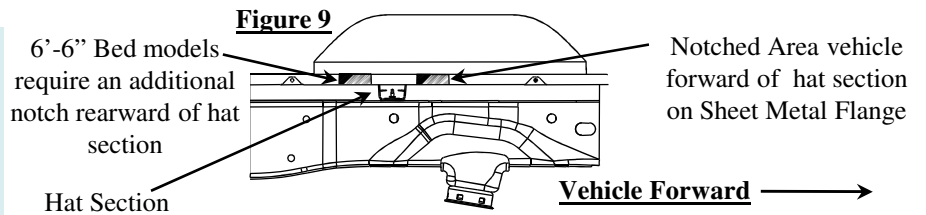

3b. Placing Crossmember Between Bed And Frame: Optional. On 8' bed models the rails can be installed from underneath the vehicle by placing one end of the **rearward** crossmember above the vehicle frame and maneuvering the opposite end above the vehicle frame. The **forward** crossmember can then be installed using the same procedure. See figure 10 for rail placement.

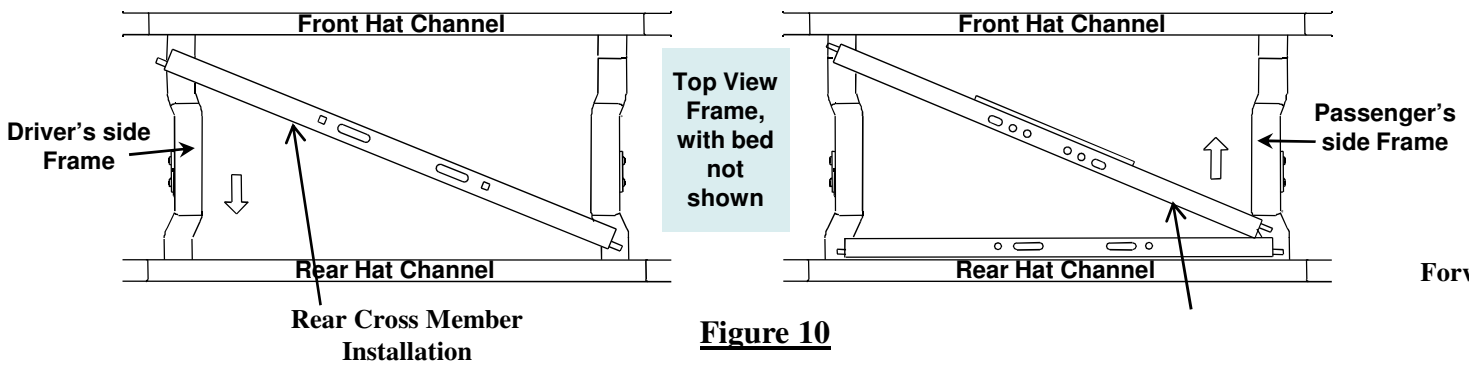

4. Fishwire 5/8 carriage bolts and 1/4 X 1.13 x 3.00 blocks through the large holes in the vehicle frame rails and through the smaller attachment holes in the frame rails.
5. Position the hitch frame brackets using the hole patterns shown in figure 11 and loosely install the 5/8 conical toothed washers and 5/8 hex nuts.

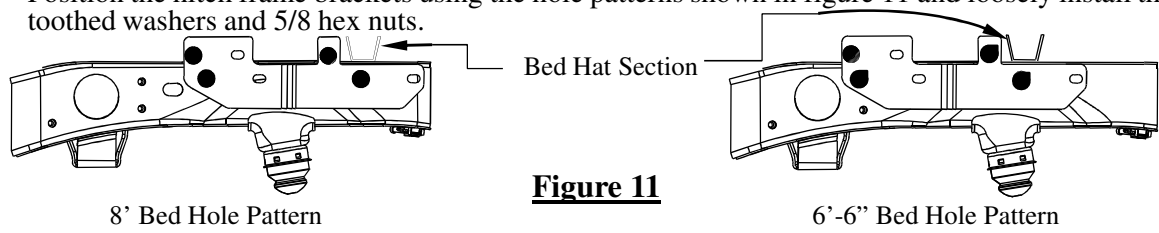

6. Align the studs on the crossmembers with the slots and holes in the frame brackets and loosely install the 5/8 conical toothed washers and 5/8 hex nuts on the studs.

7. With the cross members and side brackets properly aligned, torque all 5/8-11 GR5 fasteners on the bracket to 150 ft.-lb (203 N-m).

8. **For 6300/630044 & 8339** use the **outer** slots in the rearward cross member as a template to drill 5/8" diameter holes through the truck bed as shown in Figure 11. Due to the fuel tank, not all holes can be drilled from under the vehicle, but should be done later from inside the bed.

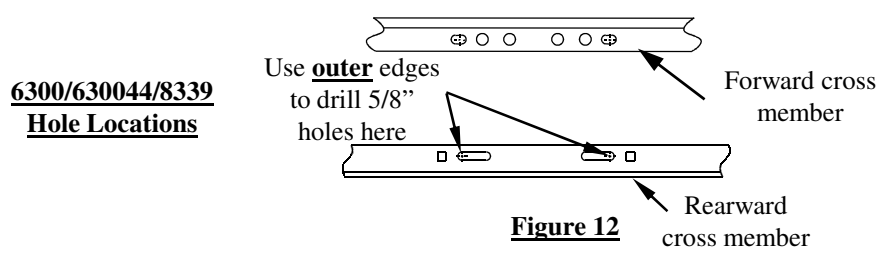

Installation Instructions

GOOSENECK MOUNTING KIT

Part Numbers:

4456

Chevrolet/GMC 2500/3500 Heavy Duty
Short & Long Bed

6300 / 630044 / 8339 GOOSENECK HITCH INSTALLATION

9. Align the holes on the template (provided with the gooseneck hitch) with the holes previously drilled through the bed. Be sure that the template is properly oriented toward the front of the vehicle (see Figure 13). Center punch the holes that will be used to cut the opening in the bed. If the vehicle is equipped with a bed liner, a section of the bed liner must be cut away so that the gooseneck platform can contact the bed corrugations.

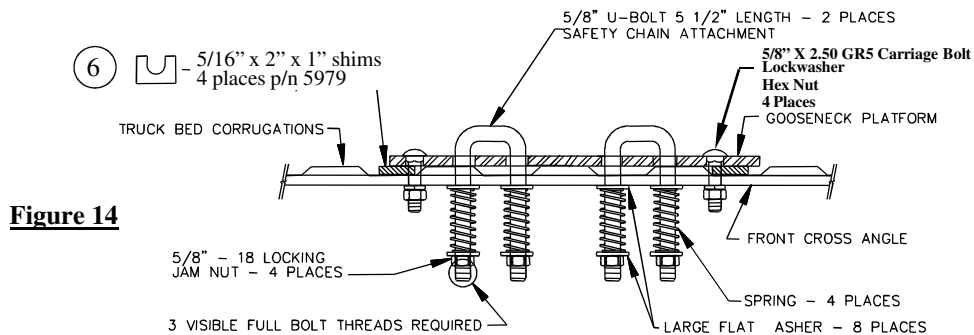
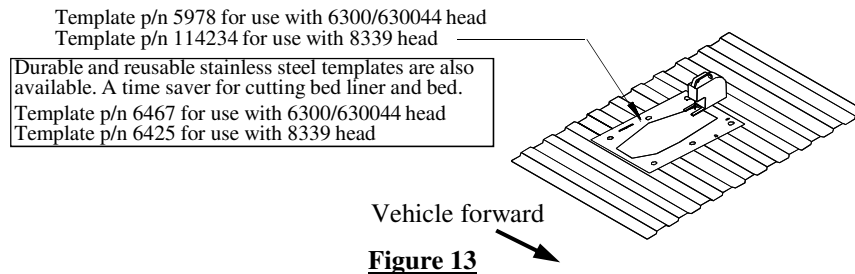

WARNING The fuel tank and/or other vehicle components are located below some of the holes. A wood or metal shield must be placed between the frame and the fuel tank to prevent puncturing the fuel tank when the drill breaks through the bed.

10. Drill 1/4" pilot holes (size will depend on width of blade in saber saw).
11. Cut out the truck bed and the bed hat section on 6'-6" bed models from underneath the bed of the vehicle and file edges as needed.
12. Install the hitch into the opening.
13. Use the hitch as a guide to drill the forward 5/8" diameter mounting holes. Also, drill 5/8" diameter U-Bolt holes if installing a 6300/630044 or 8339 gooseneck hitch.
14. Before installing the 5/8" carriage bolts through the hitch, the U-block shims must be placed between the hitch and the bed and between the cross members and the bottom of the bed. These shims are necessary to prevent the bed corrugations from collapsing when the bolts are tightened.
15. Install the 5/8 X 2.50 GR5 carriage bolts through the hitch, shims and cross members. Secure with lock washers and nuts. Torque nuts to 150 ft.-lb. (203 N-m).
16. **For 6300/630044 and 8339 Installations:** Install the (2) U-bolts through the hitch and from under the vehicle install the large flat washer over the U-Bolt followed by a spring, another large flat washer and secure with a thin 5/8" jam nut. Repeat for the other legs of the U-bolts. The 5/8" jam nuts are tightened until (3) threads are visible past the bottom of the jam nut.
17. Reinstall the fuel vapor pump if removed in installation step 2.
18. **If truck bed was raised to install rails:** Reinstall and torque bed bolts.